

# QA1

GO DRIVE IT.



DOUBLE ADJUSTABLE SHOWN

**QA1 64-73 FORD MUSTANG FRONT PRO COIL COILOVERS  
INSTALLATION INSTRUCTIONS: MS401/MD401/MS402/MD402 SERIES**

## WELCOME TO QA1!

### OUR COMMITMENT

Congratulations on your purchase of this high-quality QA1 64-73 Ford Mustang Front Pro Coil coilover kit. It is engineered to the highest standards, utilizes the finest materials, and is built with exceptional craftsmanship and attention to detail.

While we understand your eagerness to start your build, please remember that your safety is our utmost priority. Always use an approved and appropriately rated jack, jack stand, or automotive lift, and take all necessary safety precautions to ensure the job is completed safely and correctly.

Before you start, read and understand all instructions thoroughly. With hand tools and essential equipment, you can do the main assembly and setup of your new coilovers in your home garage, but if you feel unsure of your abilities during the assembly or installation and need some help or have any uncertainties, please seek the assistance of a qualified mechanic or automotive repair shop.

If you have any product questions or need guidance, please don't hesitate to call and speak with QA1 Technical Support at 952-985-5675.

Remember, we're here to support you every step of the way and are committed to ensuring your assembly and installation process is successful and enjoyable. We wish you all the best!

### BEFORE INSTALLATION

Before you begin the QA1 64-73 Ford Mustang Pro Coil coilover installation, read and understand these instructions carefully. If instructions are not correctly followed, personal injury, equipment, or product damage can result.

Products that have been installed are not eligible for returns. To prevent mistakes, thoroughly read these instructions before you start the coilover assembly procedure.

Check your order as soon as possible upon delivery. QA1 has provided parts list tables and images, as shown on pages 4 and 5. Compare your order's contents against the tables. Call your authorized dealer immediately if you discover anything missing from your order.

This kit uses fasteners to assemble and install. Welding is not required.

It is important to wear the appropriate personal protective equipment (PPE). However, the responsibility does not end there. Follow the manufacturer's instructions for safe use when working with power tools, and be cautious and responsible in your work.

**Pre-installation Note:** *Some aftermarket hoods and vehicles with an "export brace" (coilover tower brace). This type of brace can cause hood clearance issues with the upper coilover mount included in this kit. Verify for adequate hood clearance and potential interference before you begin installation.*

## ABOUT THIS MANUAL

### PURPOSE

These instructions outline the QA1 64-73 Ford Mustang Pro Coil Coilover kit.

**This system is designed to work with the factory and QA1 upper control arms (with modification).**

### ITS CONTENTS

The information that follows is described in this instruction set:

- Required tools and supplies.
- Safety, hazard, and warning rules.
- Product overview and included parts.
- Installation and the setup procedures required for use.

Pages with images will have paragraphs and sentences with callout numbers that refer to their respective images, steps, and parts.

Procedures, once described in the text, are generally not repeated. When it is necessary to refer to another procedure, the page and step reference will be given.

### REQUIRED TOOLS AND SUPPLIES

- Floor Jack
- Jack Stands
- SAE Wrench Set
- SAE Socket Set
- Torque Wrench (lb-ft)
- Coil spring compressor
- QA1 Spanner Wrench T114W or T115W
- Anti-Seize Lubricant

### SAFETY FIRST

- Work on your vehicle in an appropriate location.
- Park your car on a level surface.
- Use wheel chocks to prevent vehicle roll.
- Check your owner's manual for the correct jack lift points.
- Always support your vehicle with jack stands.
- Wear personal protection like safety glasses, gloves, and a fine particle respirator mask.
- Never use compressed air to clean brake or metal grinding dust from the brake, suspension components, frame, or rear axle housing.
- Grind metal only in a well-ventilated area, and wear a respirator until the dust has settled and the work area air has been cleared.
- Dispose of damaged or old parts in accordance with local laws. Do not throw any hazardous waste in the trash.
- Follow the manufacturer's instructions for safe use when working with power tools, and be cautious and responsible in your work.

**CONTENTS**

<b>QA1 MUSTANG PRO COIL FRONT COILOVERS .....</b>	<b>4-22</b>
<b>PARTS LIST .....</b>	<b>4</b>
<b>FACTORY SHOCK REMOVAL.....</b>	<b>6</b>
<b>COILOVER ASSEMBLY.....</b>	<b>12</b>
<b>COILOVER MODIFICATION .....</b>	<b>17</b>
<b>COILOVER ADJUSTMENT.....</b>	<b>20</b>
<b>COILOVER TUNING.....</b>	<b>21</b>
<b>WARRANTY.....</b>	<b>23</b>

64-73 FORD MUSTANG PRO COIL COILOVER KIT  
MS401/MD401/MS402/MD402

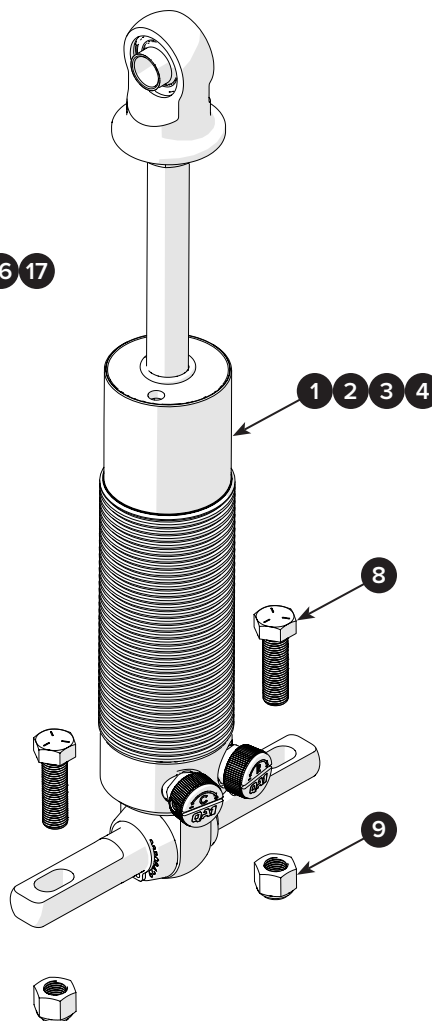
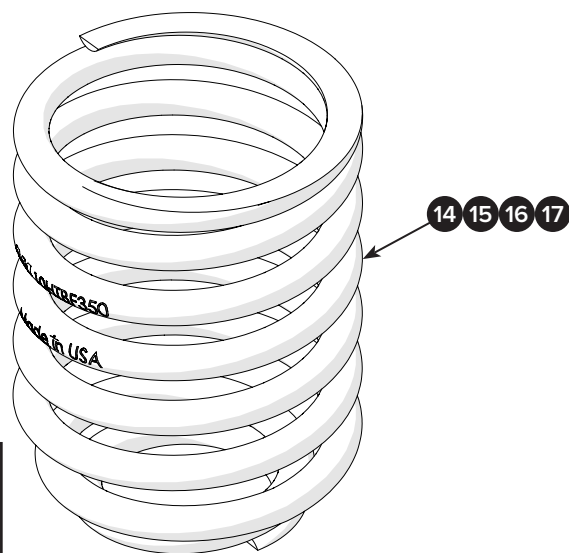
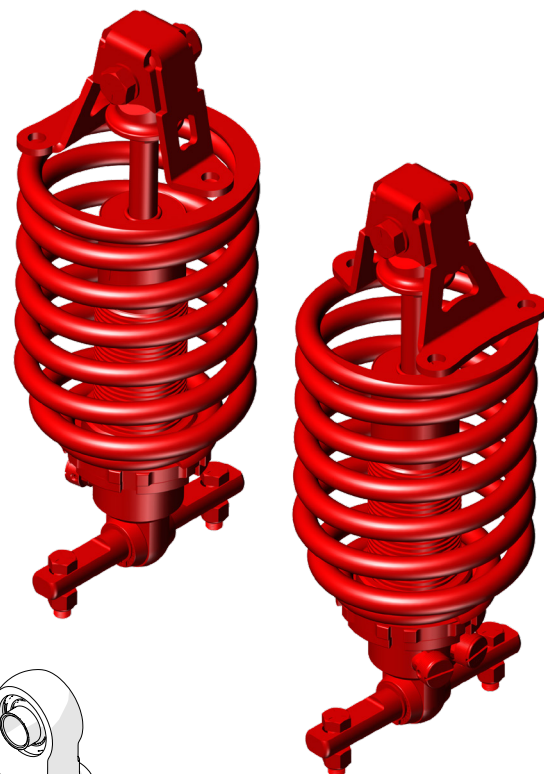
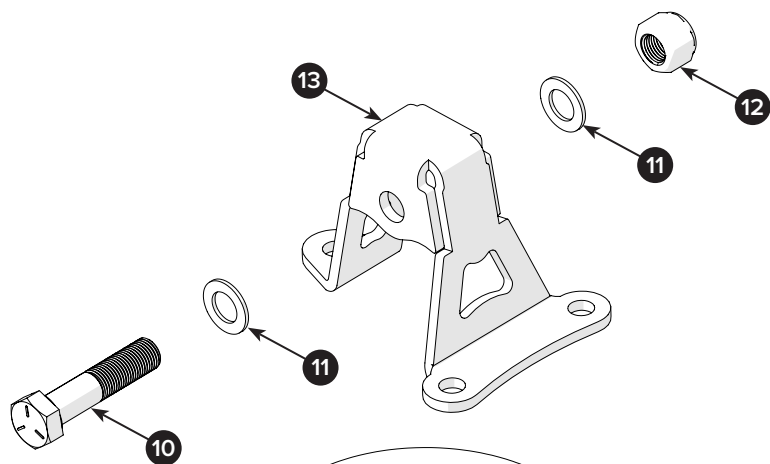

OPTIONAL  
SOLD SEPARATELY

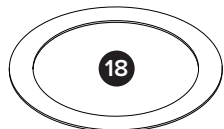
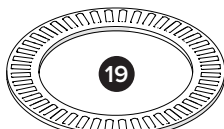
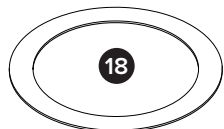

**64-73 FORD MUSTANG PRO COIL COILOVER KIT MS401/MD401/MS402/MD402**

POSITION	PART #	DESCRIPTION	COMP. LENGTH	EXT. LENGTH	QTY	U/L MOUNT TYPE
1	MS401	PROMA STAR, C-O, S-ADJ, 64-66	10.125"	14.00"	2	BRACKET/T-BAR
2	MD401	PROMA STAR, C-O, D-ADJ, 64-66	10.125"	14.00"	2	BRACKET/T-BAR
3	MS402	PROMA STAR, C-O, S-ADJ, 67-73	11.125"	15.00"	2	BRACKET/T-BAR
4	MD402	PROMA STAR, C-O, D-AD, 67-73	11.125"	15.00"	2	BRACKET/T-BAR

**64-73 FORD MUSTANG COILOVER CONVERSION KIT COK75**

POSITION	PART #	DESCRIPTION	QTY	TORQUE SPECIFICATION
5	COK75	NUT, COILOVER LOCK, 2.012" x 8 TPI	2	—
6		NUT, SPRING SEAT, 2.5", 2.012" x 8 TPI		—
7		WASHER, SPRING SEAT, 2.5" ID		—

**64-73 FORD MUSTANG UPPER CONTROL ARM HARDWARE KIT 7039-266**

POSITION	PART #	DESCRIPTION	QTY	TORQUE SPECIFICATION
8	9012-104	BOLT, HEX 3/8-24 X 1.25"	4	35 LB-FT
9	9014-108	NUT, NYLOCK 3/8-24	4	—
10	9012-269	BOLT, HEX 1/2-20 X 2.25"	2	65 LB-FT
11	9005-251	WASHER, FLAT, 1/2" AN960-816	4	—
12	NA	NUT, NYLOCK 1/2-20	2	—

**64-73 FORD MUSTANG UPPER COILOVER MOUNT BRACKET**

POSITION	PART #	DESCRIPTION	QTY	TORQUE SPECIFICATION
13	NA	COILOVER MOUNT BRACKET, UPPER	2	—

**64-73 FORD MUSTANG PRO COIL TAPERED COIL SPRINGS**

POSITION	PART #	DESCRIPTION	QTY	SPRING RATE
14	10HTBF350	COIL SPRING, HI TRAVEL, TAPERED, 4.125" x 10"L	2	350 LB
15	10HTBF400	COIL SPRING, HI TRAVEL, TAPERED, 4.125" x 10"L	2	400 LB
16	10HTBF450	COIL SPRING, HI TRAVEL, TAPERED, 4.125" x 10"L	2	450 LB
17	10HTBF500	COIL SPRING, HI TRAVEL, TAPERED, 4.125" x 10"L	2	500 LB

**QA1 2.50" COILOVER THRUST BEARING KIT 7888-109 (OPTIONAL)**

POSITION	PART #	DESCRIPTION	QTY	TORQUE SPECIFICATION
18	NA	WASHER, SPRING SEAT, 2.5" ID	4	—
19		THRUST BEARING, 63.50 MM ID	2	—

**Note:** The part positions listed above will be called out in this installation manual as a visual reference to their respective positions during the installation procedure. Refer to these pages during the installation. Count and compare all parts and fasteners to the list above. If parts are missing, contact QA1 at sales@qa1.net.



**Installer's Note:** Put the vehicle on a flat and level surface before you begin work.

**1** Begin at the front driver's side wheel of the vehicle.

To adjust your new shocks to match the current ride height, it must first be measured before the wheels are removed.

Use a measuring tape to measure the distance (A) from the bottom lip of the front fender to the wheel hub, and record this measurement in the table below.

Repeat this process for the passenger's side wheel.

**STARTING RIDE HEIGHT**

LEFT SIDE	RIGHT SIDE

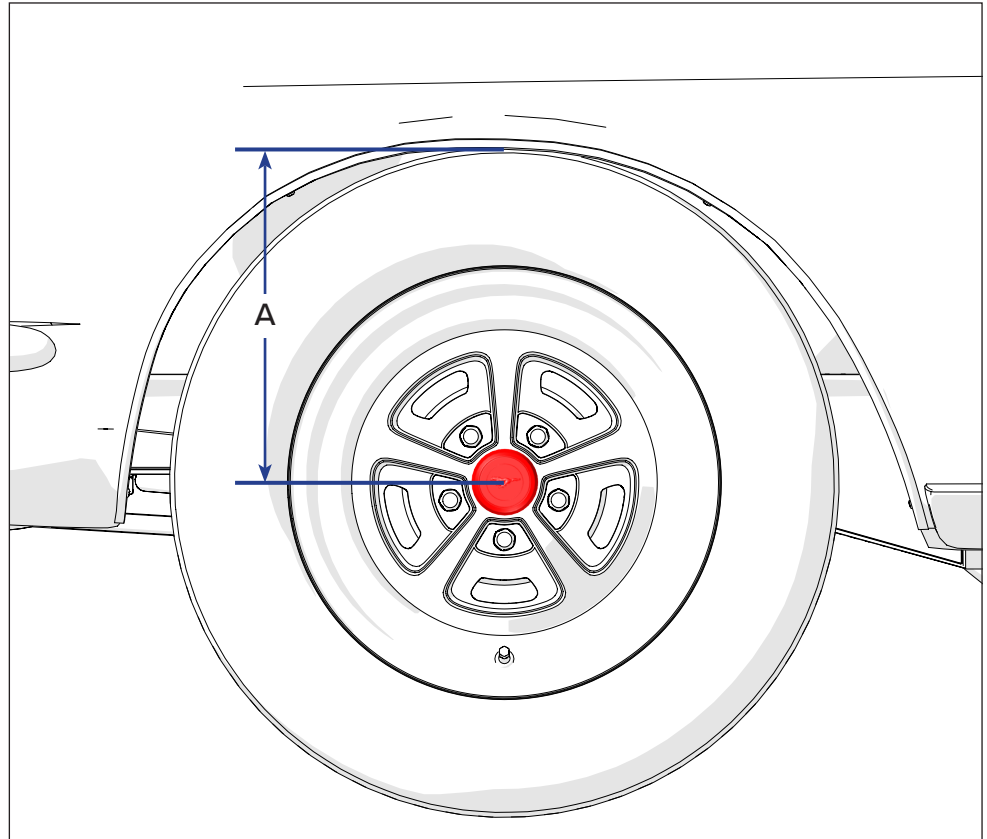

It is recommended to use the final wheel and tire package for the best visual fitment against the fender's wheel opening.

**Installer's Note:** This instruction set begins with the replacement procedure for the coilover shock on the front driver's side.

The process to replace the passenger side coilover shock is identical.

**2** Lift the front of the vehicle and securely support it with jack stands.

Next, remove the lug nuts and wheels from both the left and right sides of the front of the vehicle.

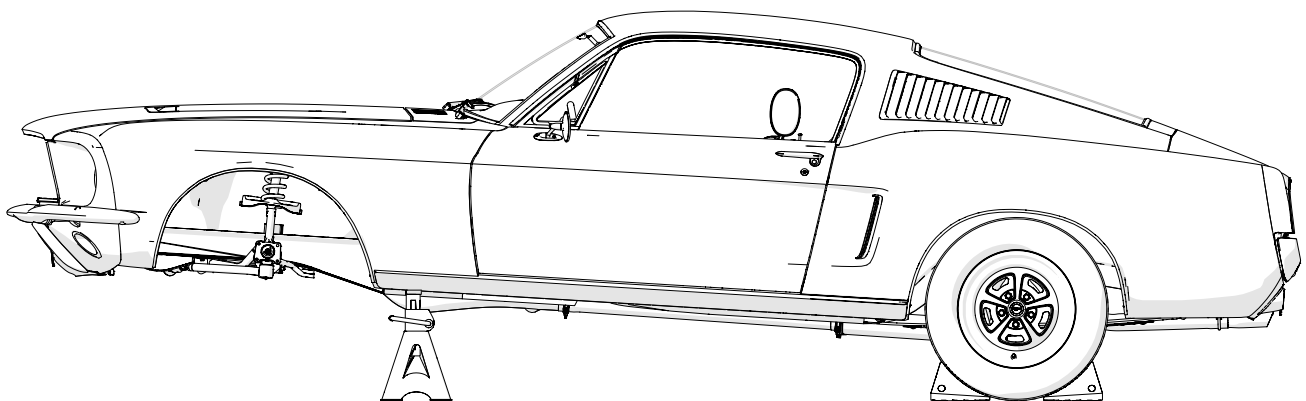
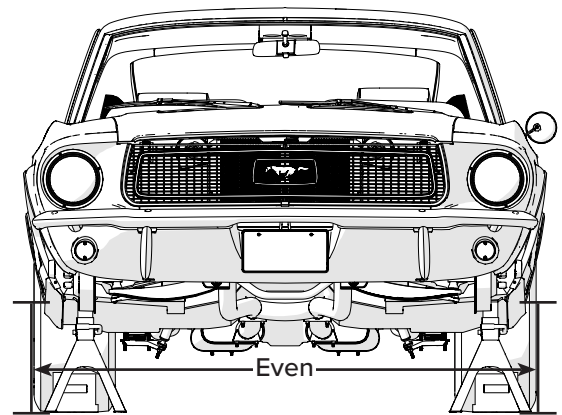

**Installer's Note:** The images in these instructions show the QA1 Lower Control Arm and Sway Bar kits. These kits are available from QA1, along with the QA1 Upper Control Arm for the 1964-1970 Mustang. Contact QA1 Technical Support for more information.

QA1 does not currently manufacture Upper Control Arms for the 1971-1973 Mustang models. Factory control arms must be used.

- 3** First, use a floor jack to lift the lower control arm and relieve the pressure from the suspension.

**Note:** The floor jack must remain under the lower control arm until step 9.

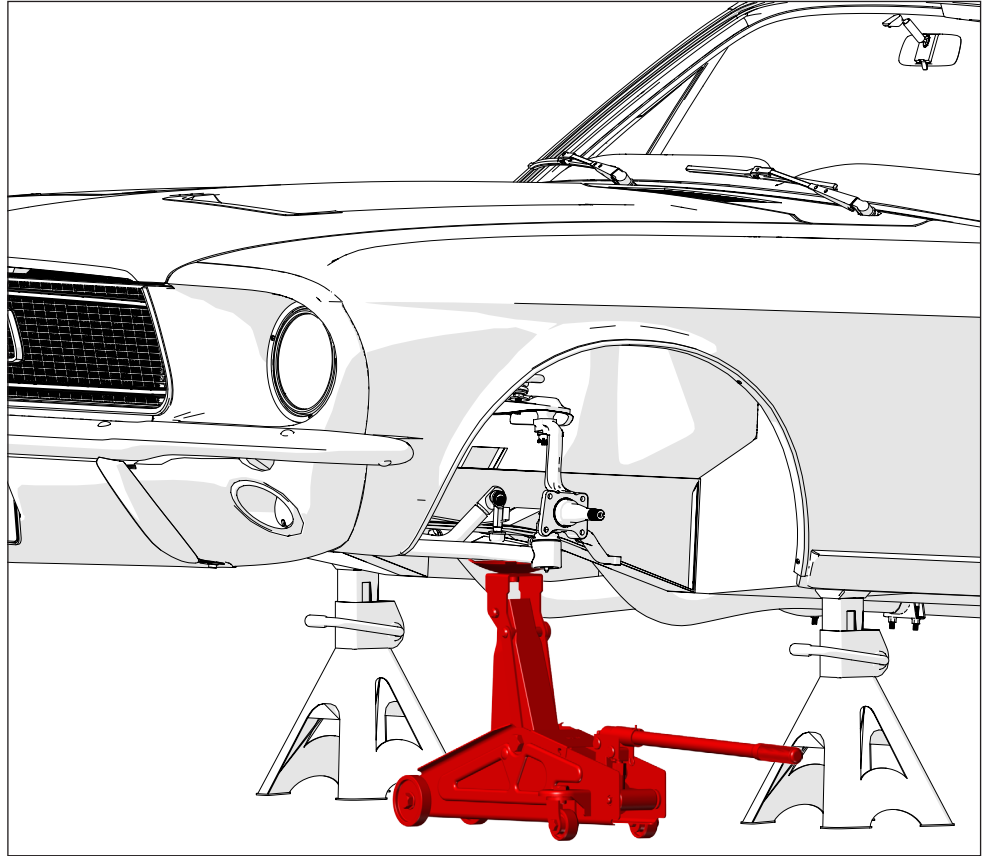

- 4** Then, remove the nuts, shock washers, and rubber shock isolators from the shock T-bar and coil spring trunnion fastened to the upper control arm.

**Note:** Discard the hardware as it will not be reused.



To make it easier to install the coilover shocks, disconnect the sway bar from the lower control arm if it is installed.

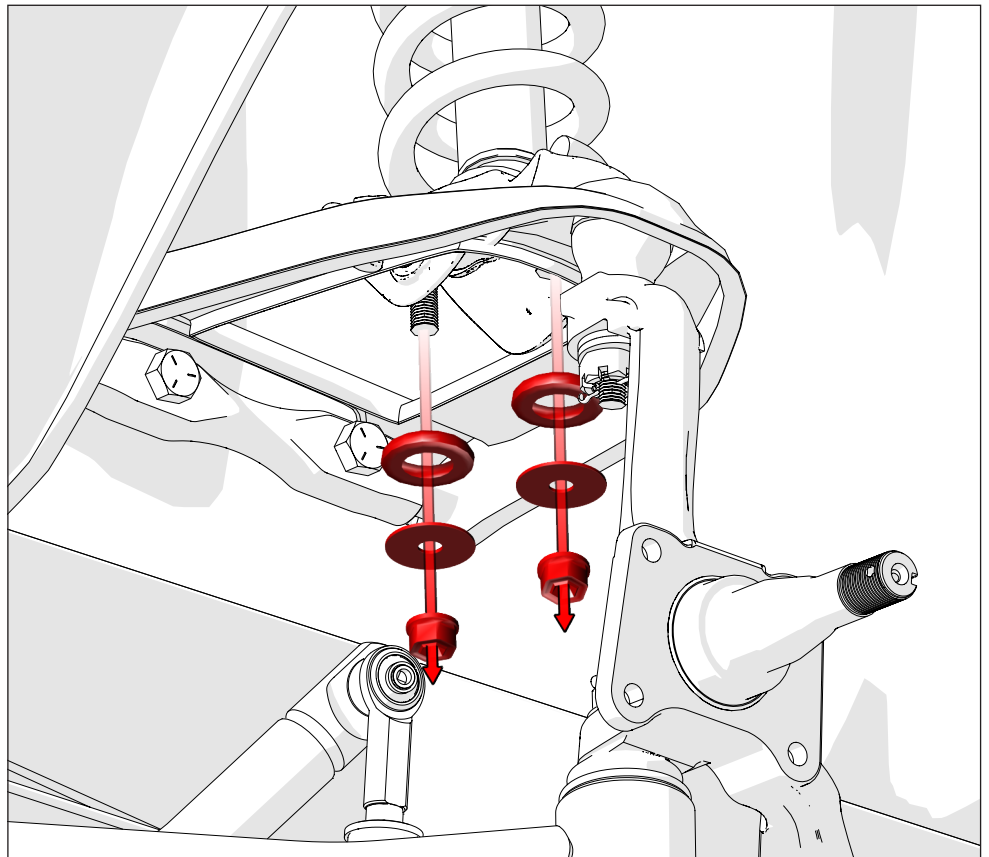

- 5** Open the hood to access the inner fenders and the shock tower tops. Then, remove the two bolts and washers from the shock tower top (LH shown). Discard the hardware, as it will not be reused.

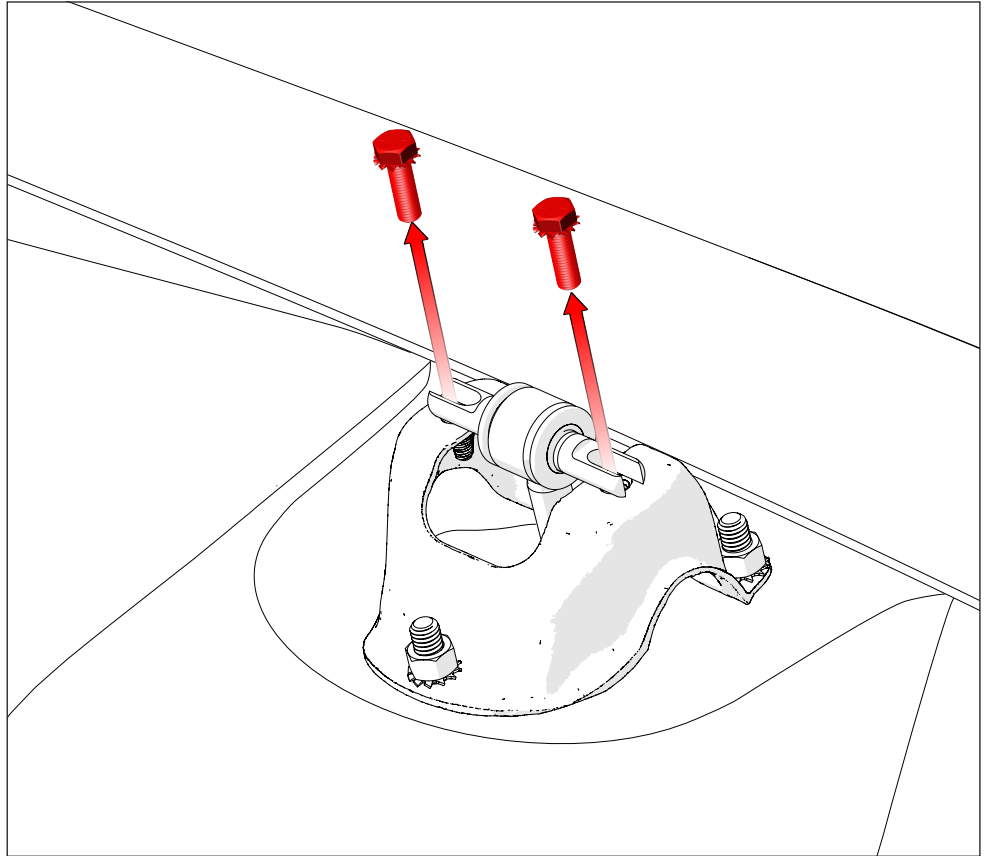

- 6** Next, remove the three shock tower nuts and washers from the inner fender. Save this shock hardware as it will be reused.
- Note:** Replace the nuts and washers if they are corroded or if there is damage present.

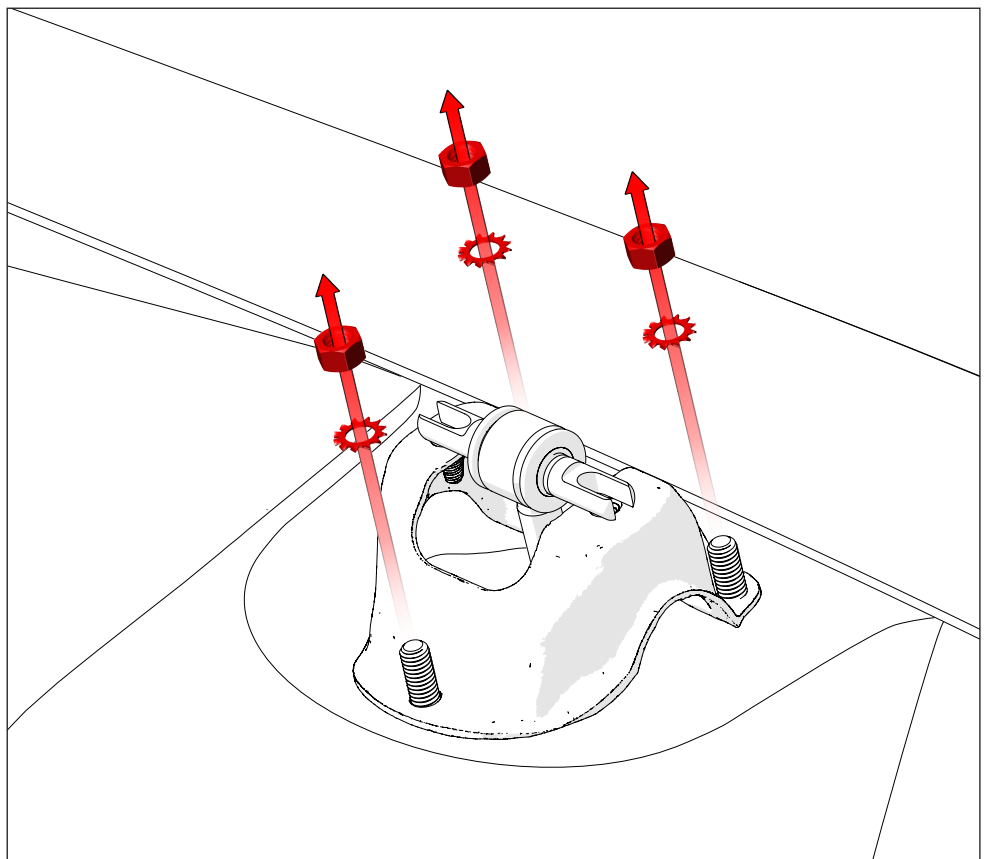

**7** Then, pull the shock assembly out through the inner fender.

Now, remove the shock tower top from the inner fender and the carriage bolts.

Discard the shock assembly and shock tower top, as they will not be reused.

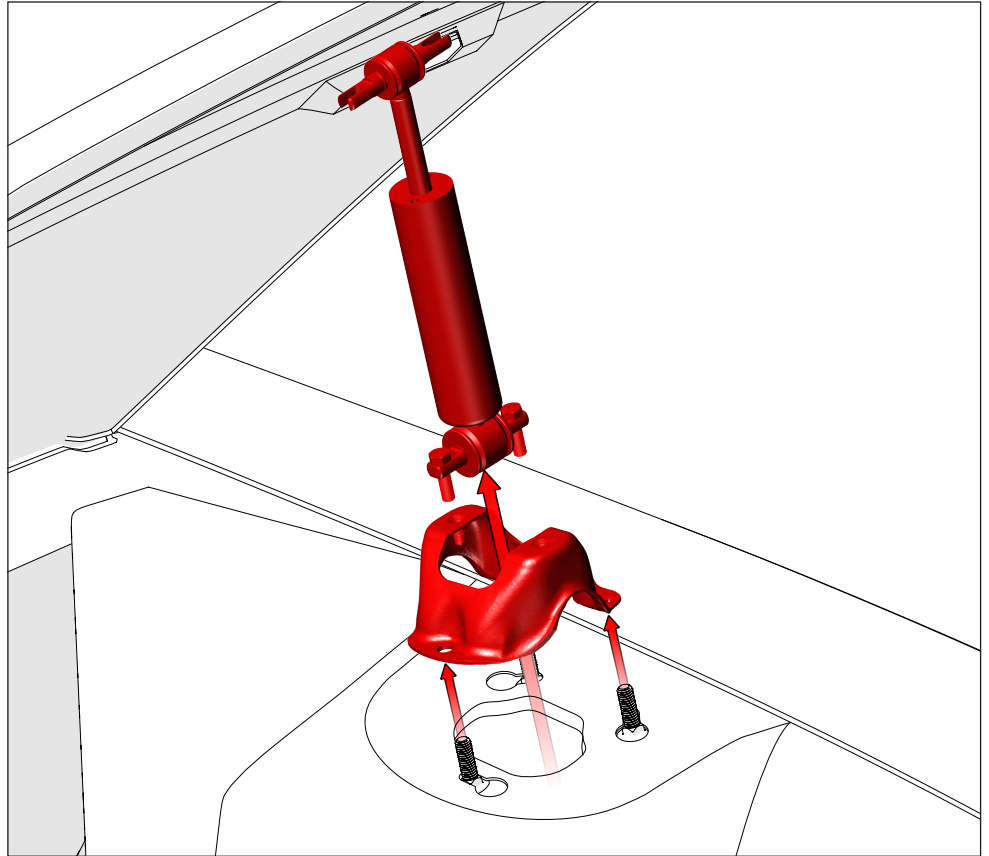

**8** Finally, remove the shock tower carriage bolts from their respective slots in the inner fender.

Set aside the bolts as they will be reused.

**Note:** Replace these carriage bolts if they are corroded or if there is thread damage present.

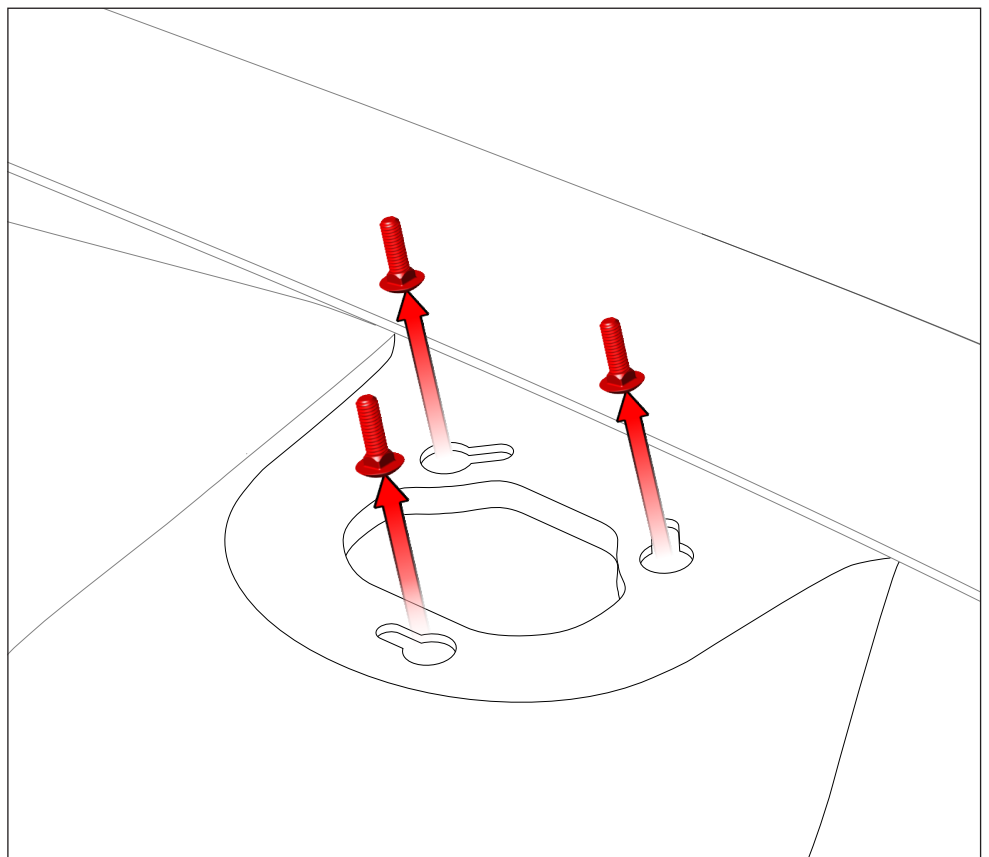

**Installer's Note:** A coil spring compressor is a tool used to safely compress coil springs, as found in vehicle suspension systems.

These springs store a significant amount of potential energy, and due to the possible risk of injury associated with removing coil springs, QA1 recommends the use of coil spring compressors for best safety practices.

9

With the shock removed, insert a coil spring compressor inside the coil spring from the top opening of the inner fender.

Compress the spring until the bottom of the spring can be easily moved on the upper control arm's spring trunnion.

Next, lower the floor jack to relieve any stored energy and pressure from the upper control arm (UCA) to the coil spring.

Finally, with the spring compressed, remove the two bolts that hold the lower spring saddle to the UCA.

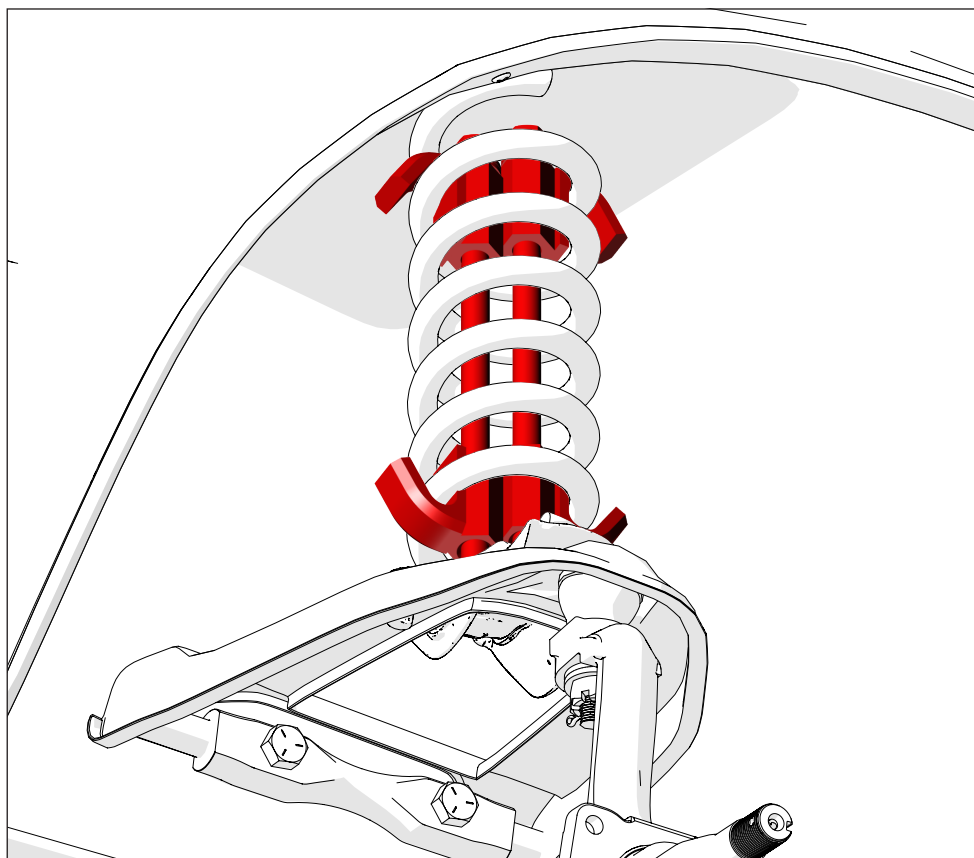

10

Now, slowly lower the floor jack to relieve pressure from the control arm and knuckle assembly.

Safely remove the compressed coil spring from the inner fender.

Discard the coil spring, as it will not be reused.

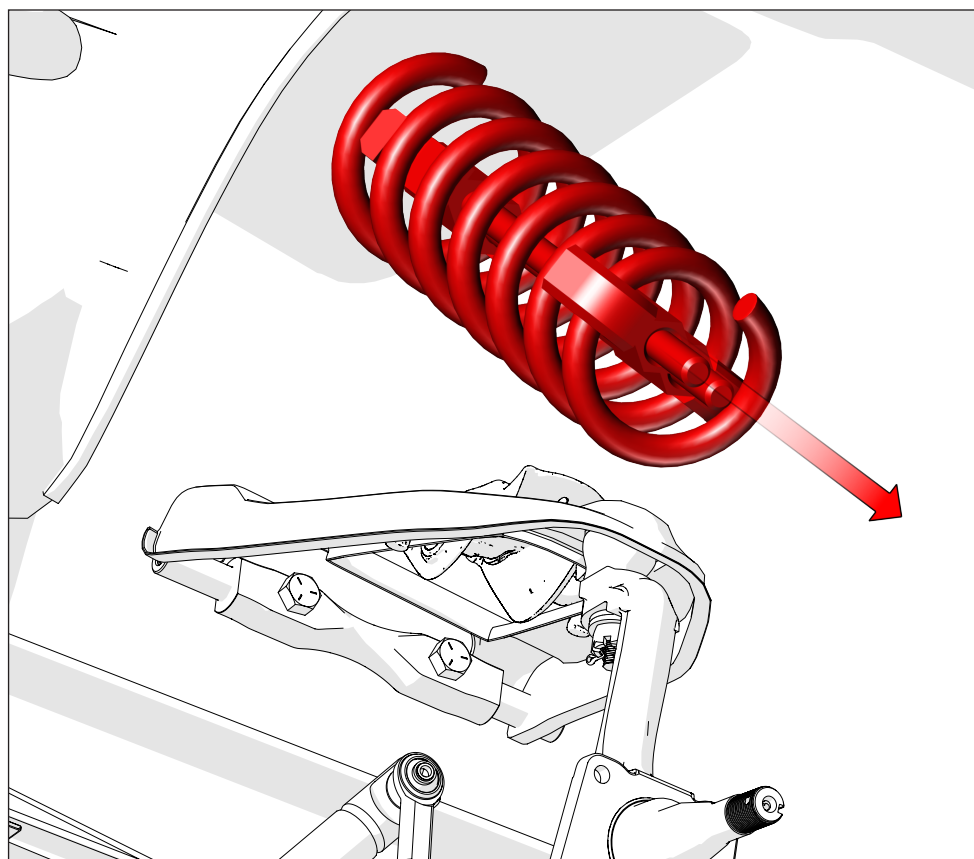

11

Remove the nuts from the coil spring trunnion attached to the UCA and discard them, as they will not be reused.

Remove the spring trunnion and discard it, as it will not be reused.

**Note:** The factory trunnion uses pressed-in studs. If yours uses bolts, discard them as they will not be reused.

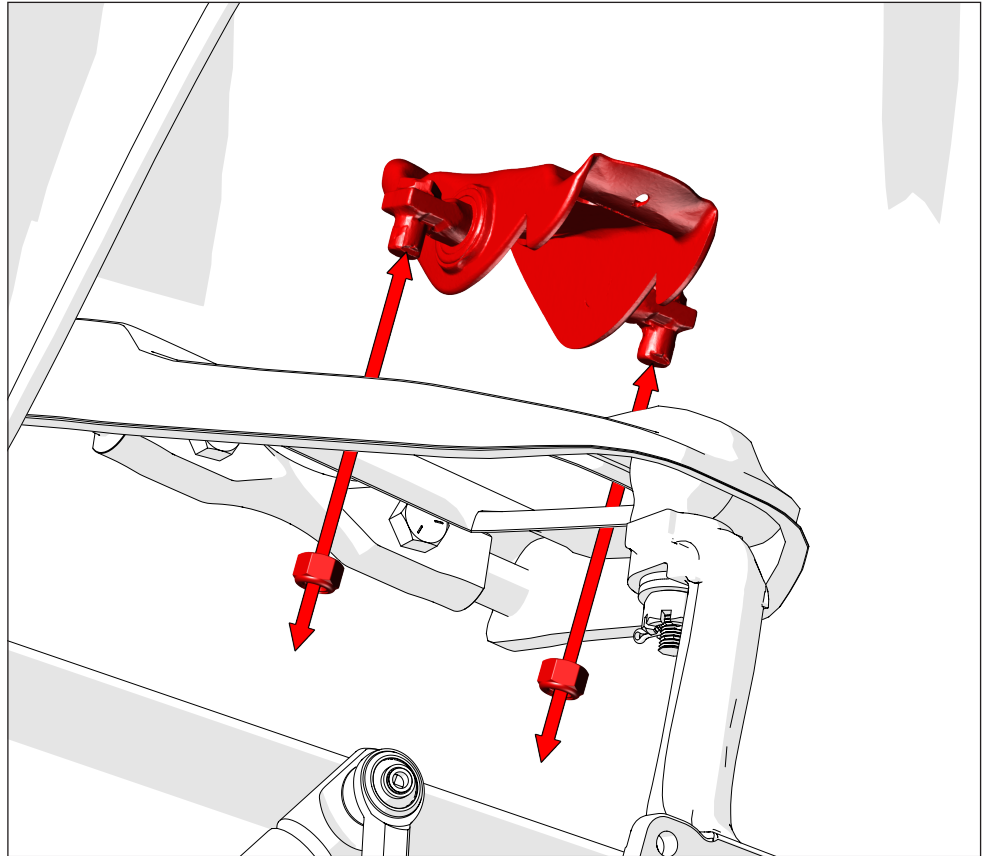

12

Remove the coil spring compressor.

Carefully remove and set aside the upper spring isolator. It will be reused for the QA1 coilover.

**Note:** If the isolator is damaged, discard it and use a new one.

Repeat steps 3 through 12 to remove the passenger side shock.

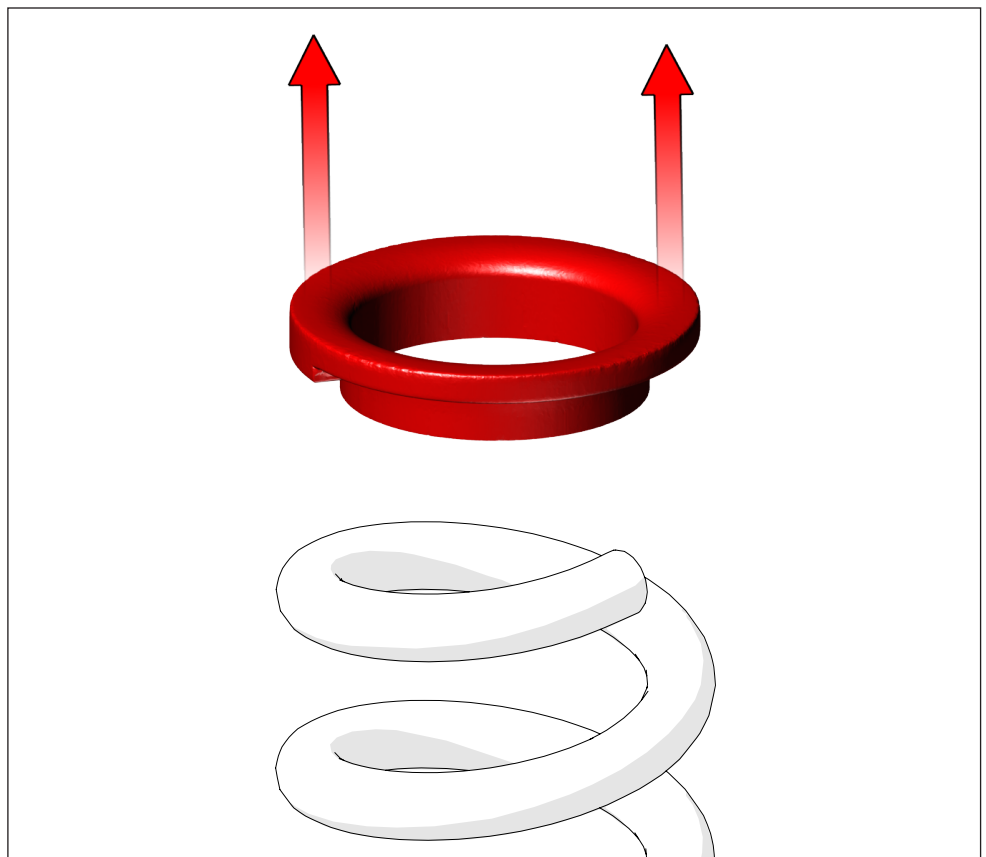



Stop here if the QA1 UCA will be used, as the coilover must be modified. Go to step 23 to make these modifications.



If your vehicle will use the factory UCA, proceed to step 13.

**13**

If the thrust bearing kit will not be used, put the lock nut (5) and spring seat (6) onto the coilover body (1, 2, 3, or 4) in the order shown. Position the lock nut and spring seat on the last thread on the coilover housing.

Make sure that the raised protrusion (marked in green) on the lock nut faces upward toward the spring seat.

Then, lightly apply a thin layer of anti-seize to one side of the spring seat washer (7), and put the washer onto the spring seat so the anti-seize lubricates the spring seat.

Proceed to step 15.

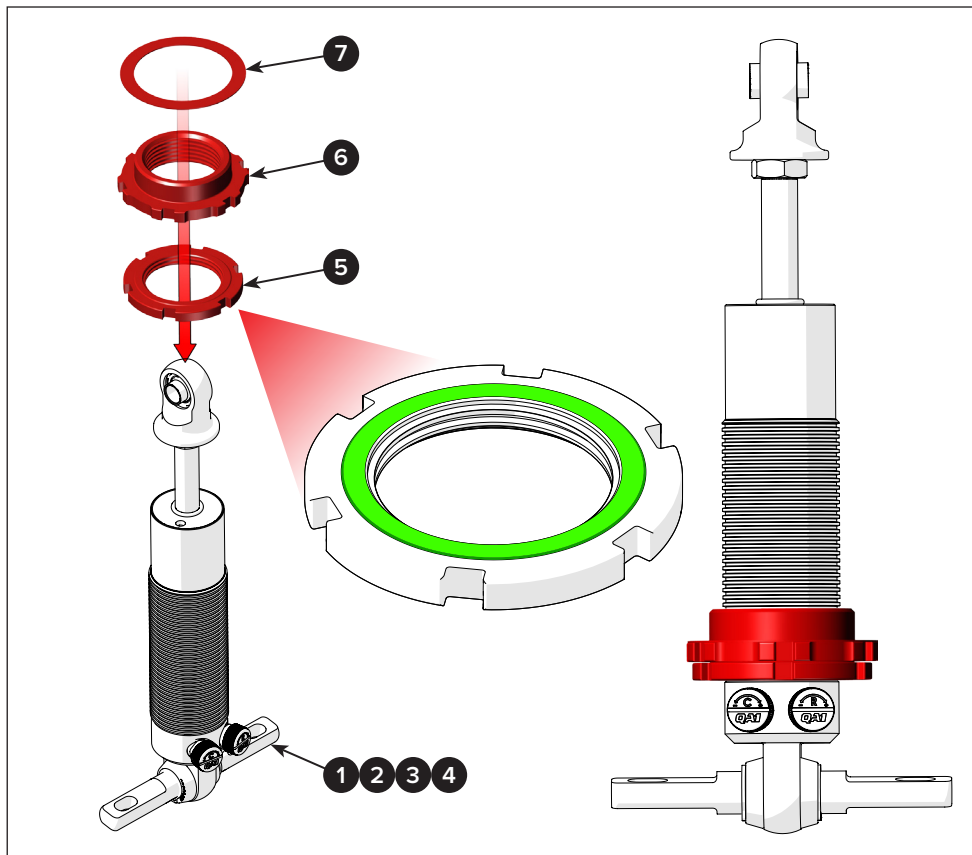

**Installer's Note:** For ease of adjustment, QA1 highly recommends the QA1 thrust bearing kit P/N 7888-109.

**14**

If the thrust bearing kit is used, put the lock nut (5) and spring seat (6) onto the coilover body (1, 2, 3, or 4) in the order shown.

Make sure that the raised protrusion (marked in green) on the lock nut faces upward toward the spring seat.

Set the lock nut and spring seat to the last thread on the coilover housing.

Then, lightly apply some anti-seize lubricant to the top and bottom sides of the spring seat washers (18).

Next, install one spring seat washer onto the spring seat with the anti-seize face up.

After that, place the thrust bearing (19) onto the first washer.

Finally, add the spring seat washer onto the thrust bearing with the anti-seize face down.

Proceed to step 15.

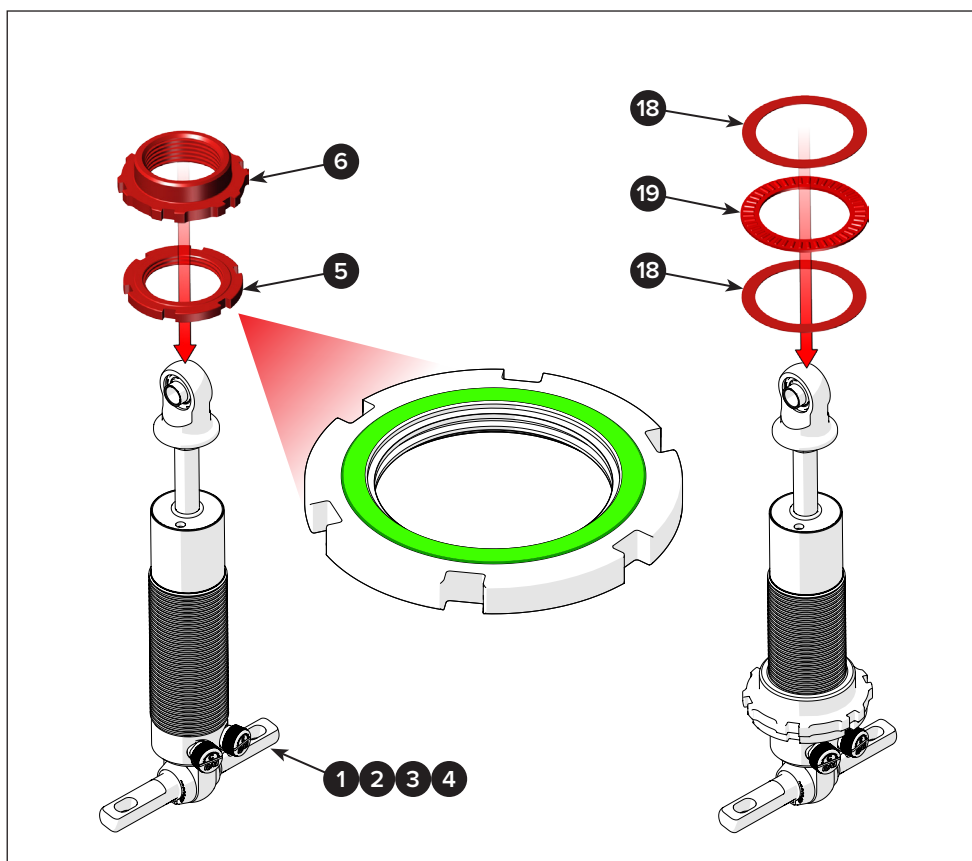

**15** To prevent galling during adjustment, apply a thin layer of anti-seize to all threads above the spring seat (shown in green).

Next, place the coil spring (14, 15, 16, or 17) onto the coilover's spring seat.

**Note:** The small end of the spring faces down. It must make contact with the spring seat.

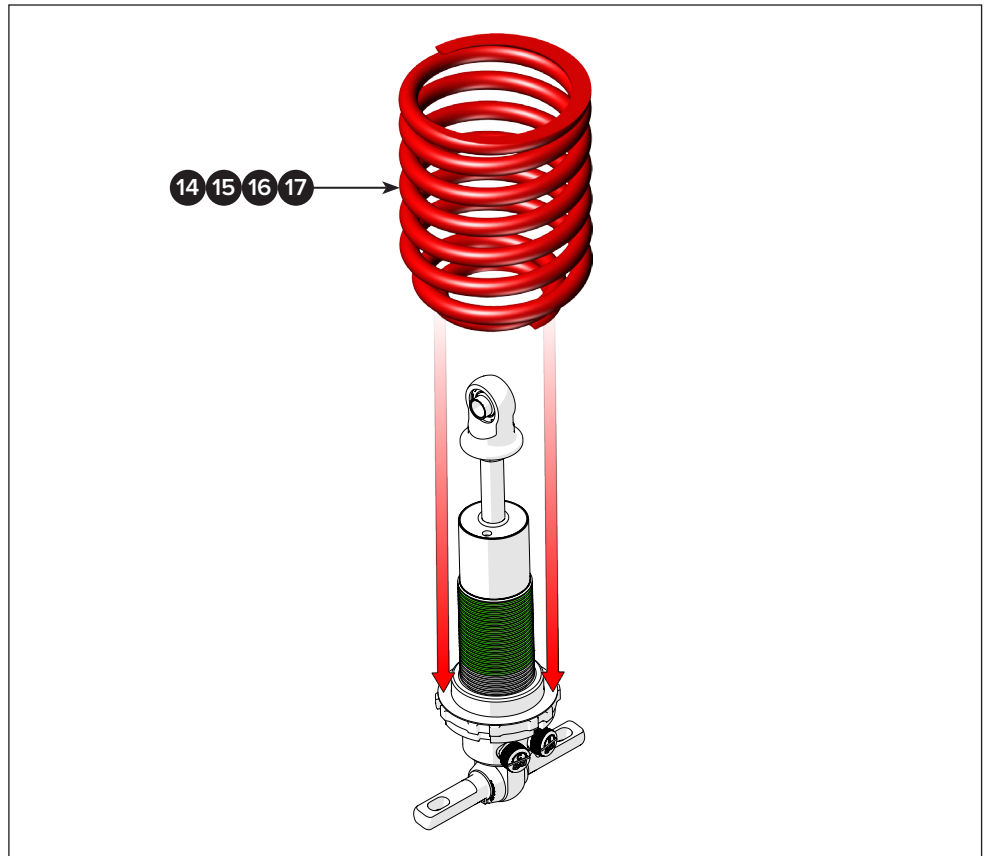

**16** Place the spring isolator, which was removed during step 12, on top of the coil spring.

Make sure to align the notch in the isolator with the spring's top.



- 17** Next, install the shock tower carriage bolts removed during step 8 into the slots in the inner fender. Push the bolts into the small ends of the slots until they are fully engaged.

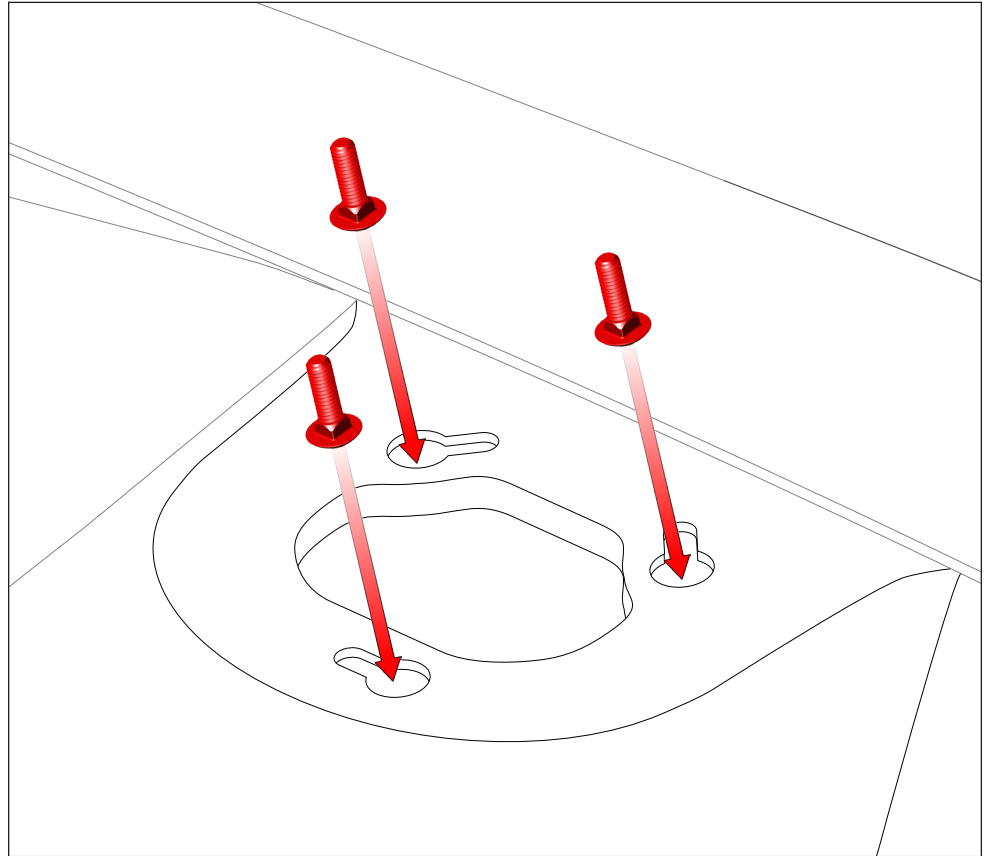

**Installer's Note:** Refer to the parts list to complete the coilover installation from here to step 22.

- 18** First, put the new QA1 coilover tower (13) onto the studs.

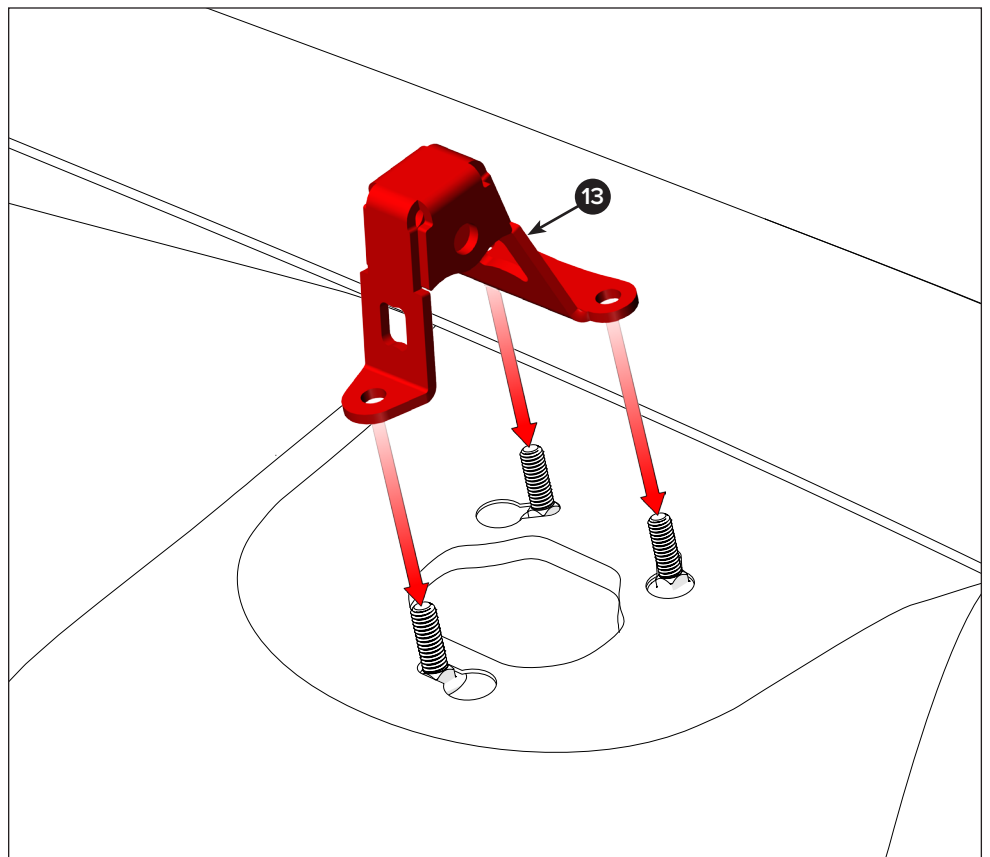

19

After that, put the washers and nuts removed during step 6 onto the carriage bolts.

Torque the nuts to 26 lb-ft.

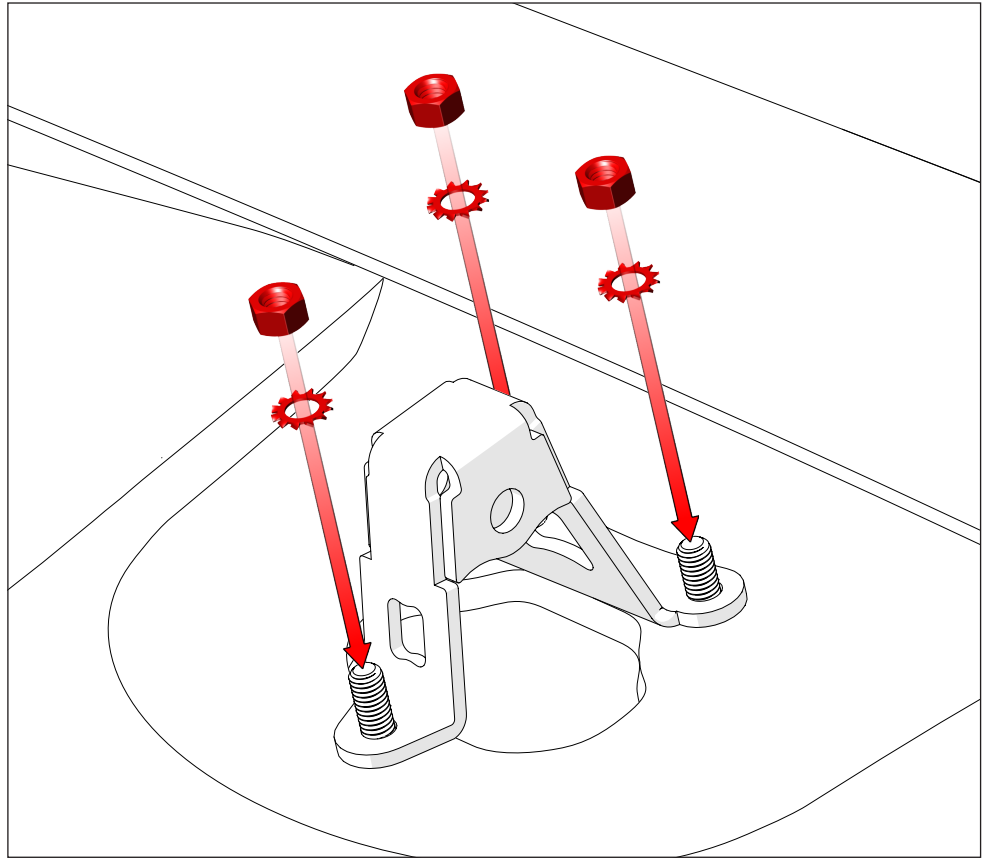

20

To install the coilover, first turn the coilover adjustment knob(s) counter-clockwise to the softest setting.

Then, pull the piston rod out to full extension.

Now, insert the top of the coilover assembly through the shock opening in the inner fender (not shown).

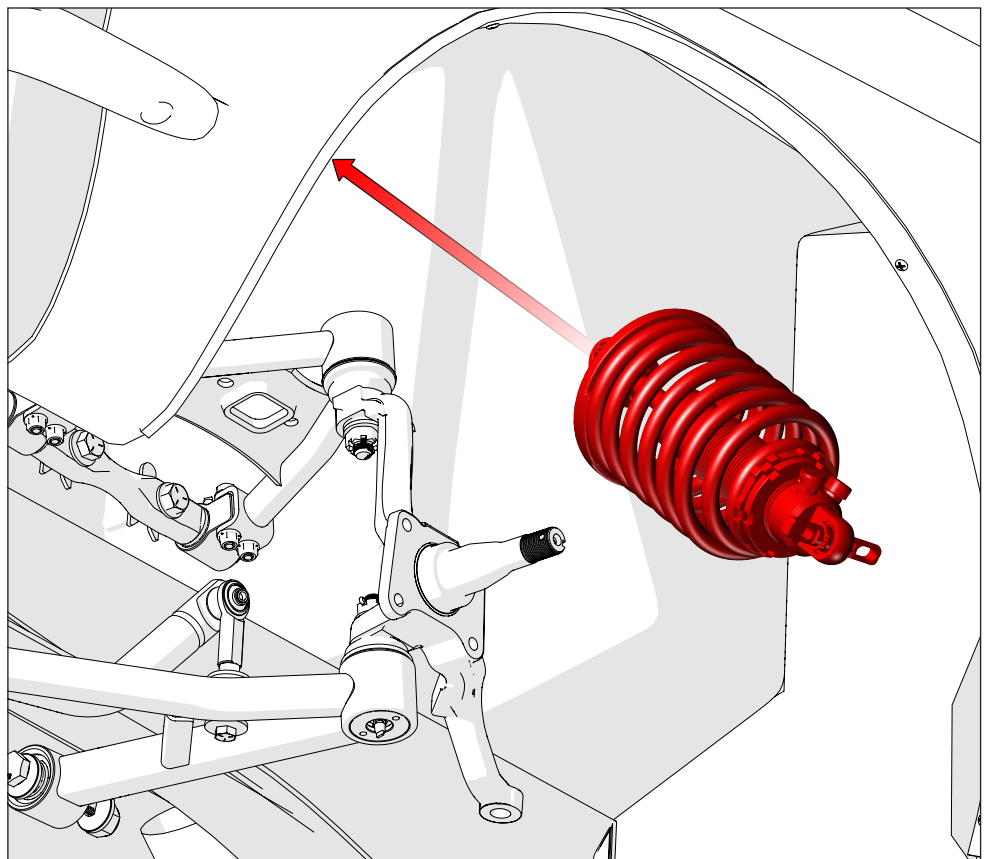

21

Next, insert the top of the coilover assembly through the shock opening in the inner fender.

Attach the coilover to the coilover tower with one 1/2" x 2.25" bolt, two flat washers, and one 1/2" Nylock nut.

Torque the bolt to 50 lb-ft.

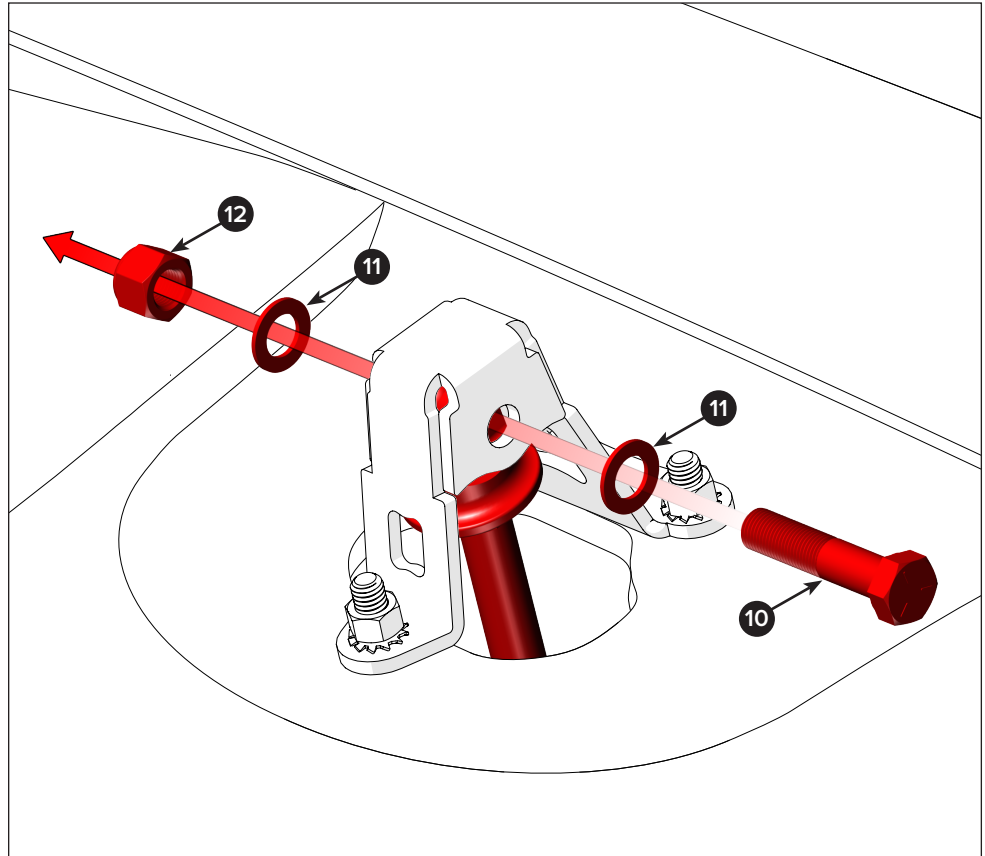

22

Align the slots on the lower coilover T-bar with the holes on the upper control arm.

Insert two 3/8" x 1.25" hex bolts (8) through the T-bar and control arm.

Attach the bolts with two 3/8" Nylock nuts (9) and torque them to 35 lb-ft.

Repeat steps 12 through 20 to install the RH coilover assembly.

Make sure to attach the sway bar if it was disconnected during step 4.

Once both coilovers are installed, go to step 29 to adjust your ride height.

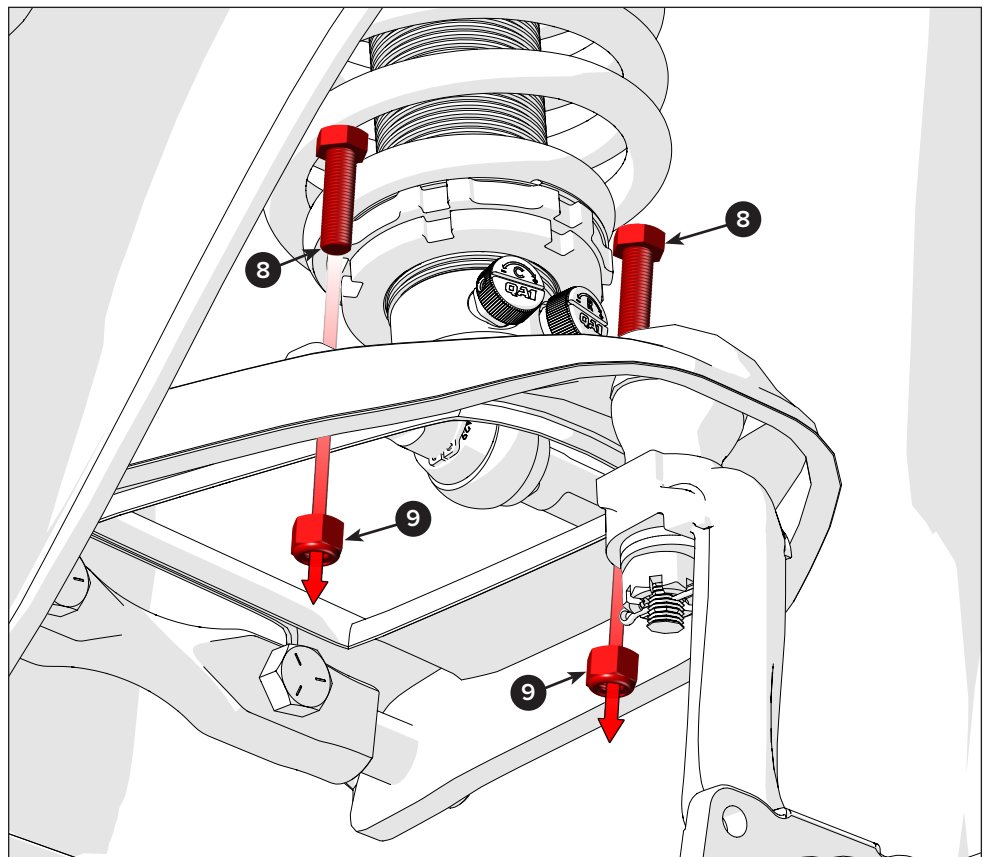

**Installer's Note:** The QA1 Mustang coilovers included in your system are designed to fit directly with the factory control arms. They will require modifications to fit on the QA1 upper control arms.

The QA1 UCA arm kit includes all the necessary parts to adapt the coilovers for use with the QA1 upper control arms. The steps that follow will provide instructions to make that conversion.

**23** First, remove one outer retaining ring with an external snap-ring pliers.

Then, push the cross pin out of the urethane bushing.

Discard the cross pin and retaining rings, as they will not be reused.

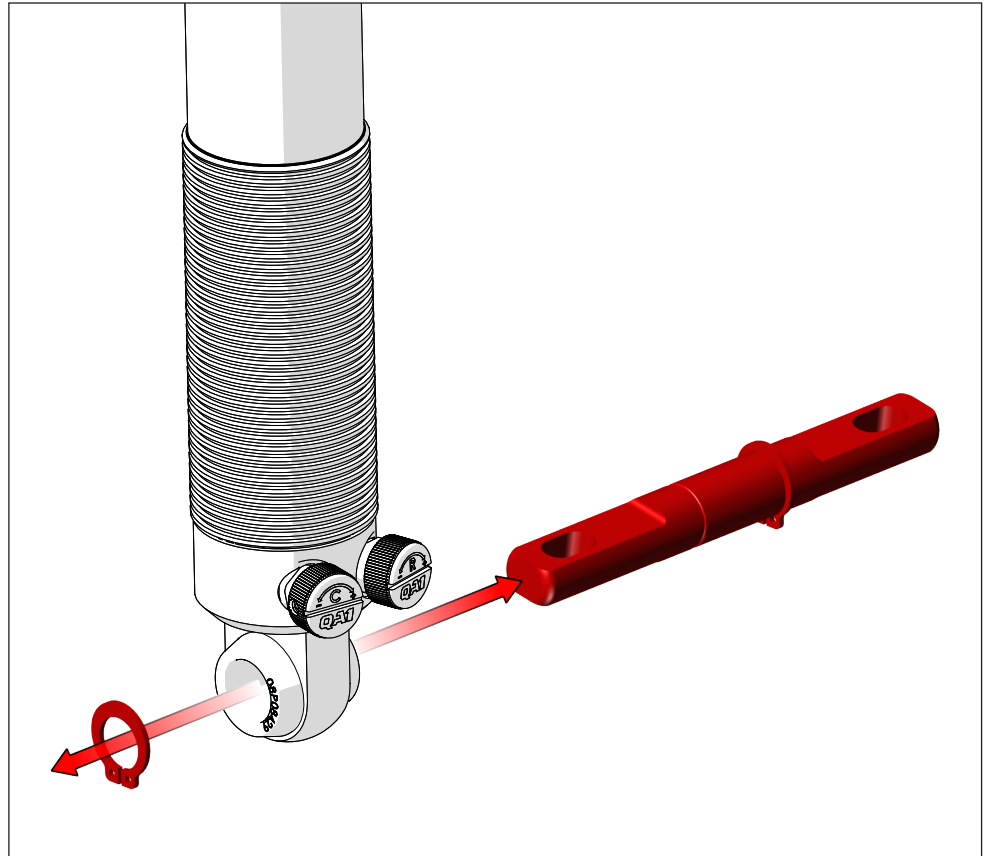

**24** First, remove the urethane bushing from the lower coilover eyelet. This bushing is machine-pressed into the shock base and is difficult to remove by hand.

To make the process easier, QA1 recommends a box cutter (shown in teal) or a similar cutting tool with a fresh, sharp blade.

Carefully cut through one side of the bushing as close to the coilover base as possible.

**Note:** To avoid damage to the anodized finish, keep the blade parallel to the coilover base and apply firm pressure as it cuts through the bushing.

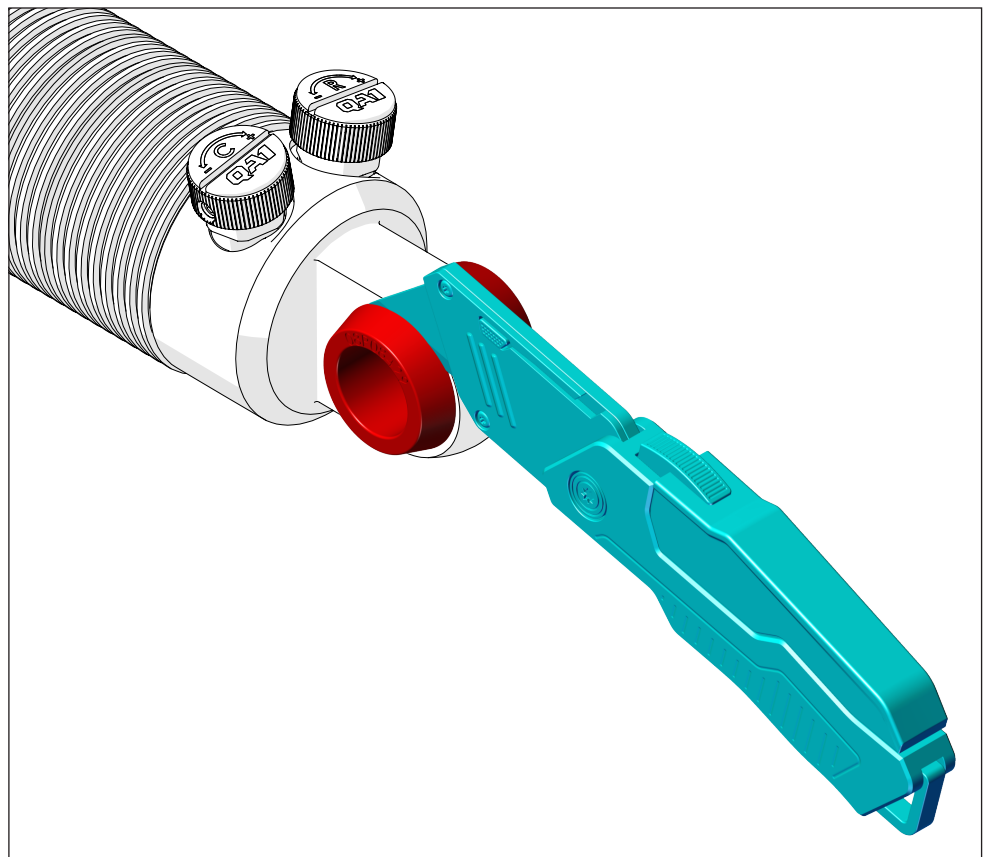

- 25** Remove the remaining bushing from the coilover eyelet. Discard it, as it will not be reused.

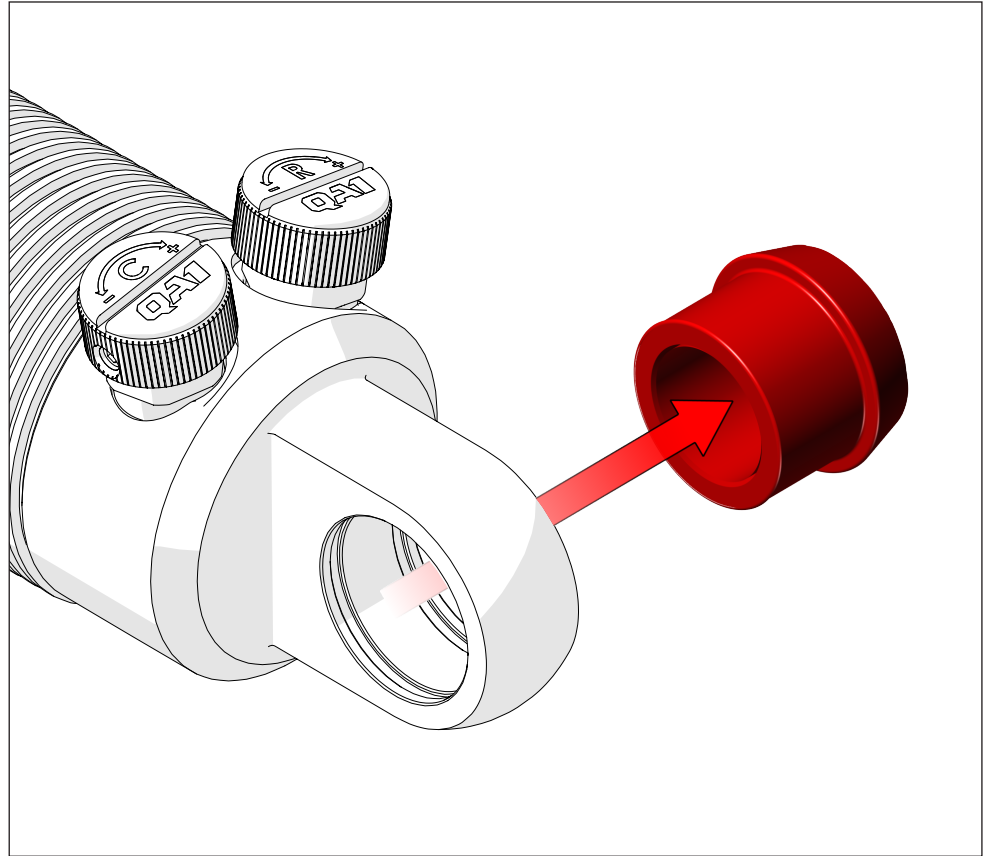

- 26** Fit one internal retaining ring into the ring groove (marked in green) in the coilover base.

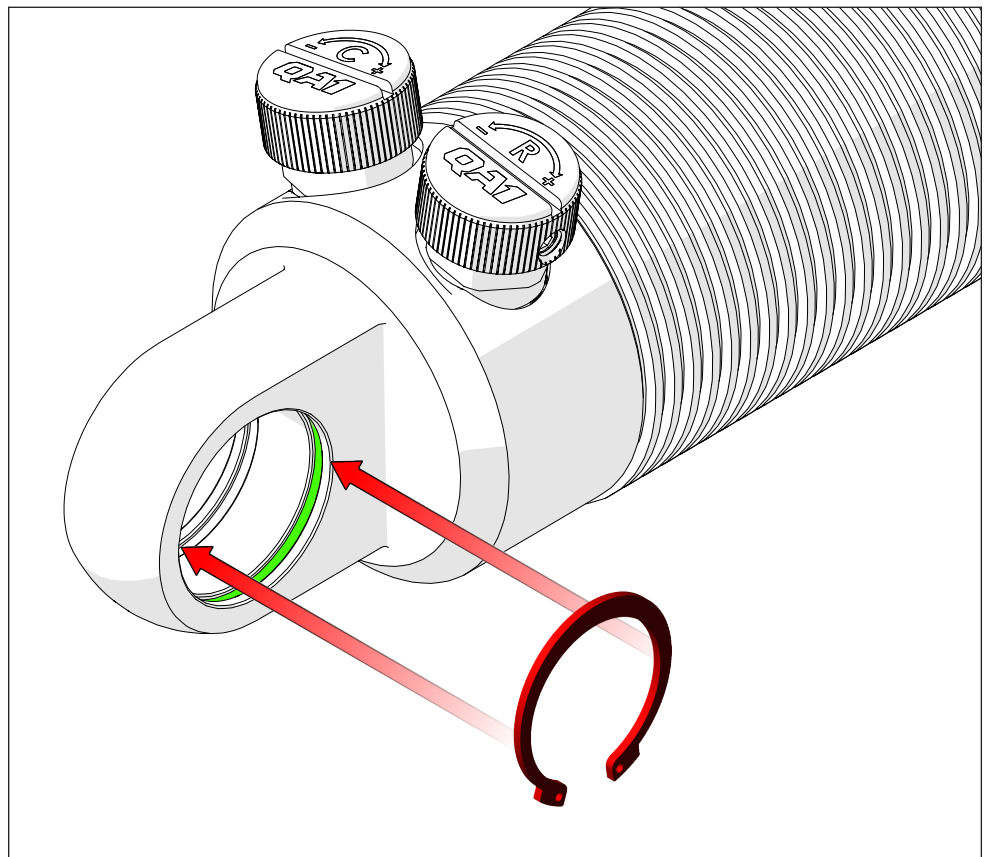

- 27** Now, insert the cross pin assembly into the bore in the coilover base until it fully contacts the retaining ring.

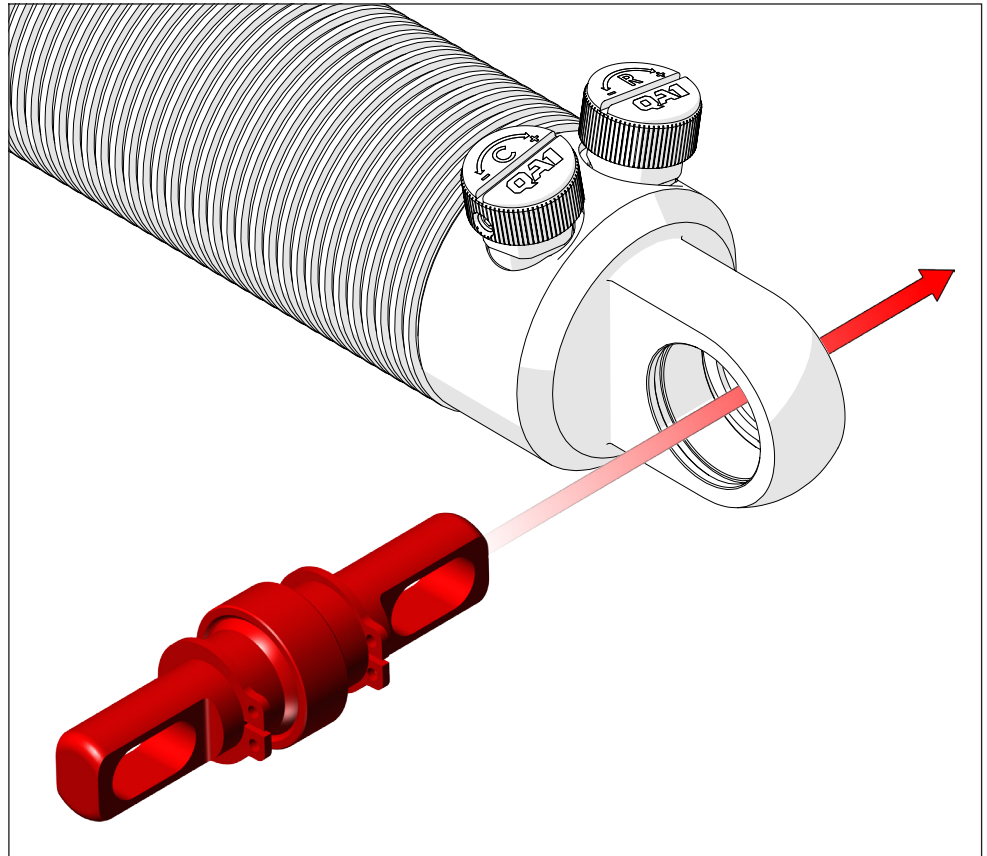

- 28** Next, insert the second internal retaining ring into the ring groove of the coilover base (shown in green).

**Note:** This retaining ring has a tight fit. Use a rubber mallet and a drift pin to make sure it is fully seated in the groove.

Repeat steps 23 through 28 to modify the other coilover assembly.

Now, return to step 13 to build and install the coilover.

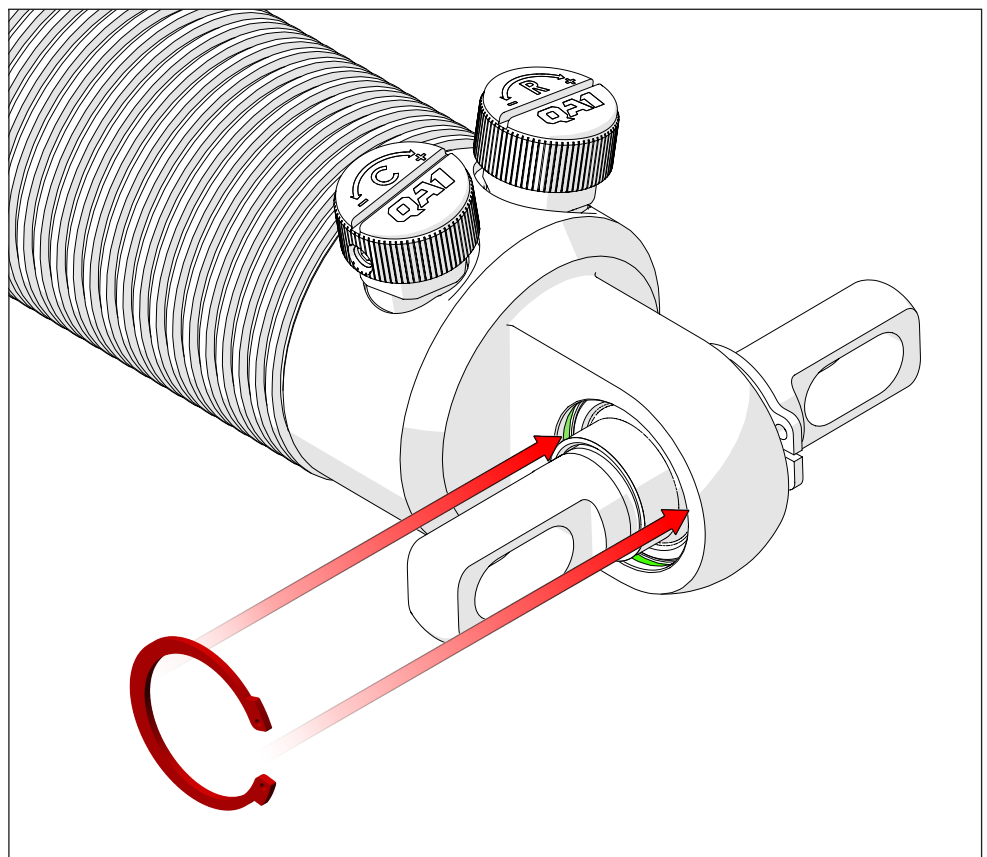

29

To adjust the ride height of your new QA1 coilovers, follow these steps:

First, put the wheels back onto the hubs and torque the lugnuts to specification.

Next, remove the jack stands and lower the car to the ground.

Now, roll the vehicle back approximately 10 feet, then forward again. This action will settle the wheels and suspension.

After that, bounce the left and right front corners of the vehicle to seat the new coil springs.

**Note:** If you want to set the vehicle to factory ride height, measure the current ride height with the new coilovers installed and compare it to the measurements recorded in the table from step 1.

Go to step 30 to adjust the springs to set the height.

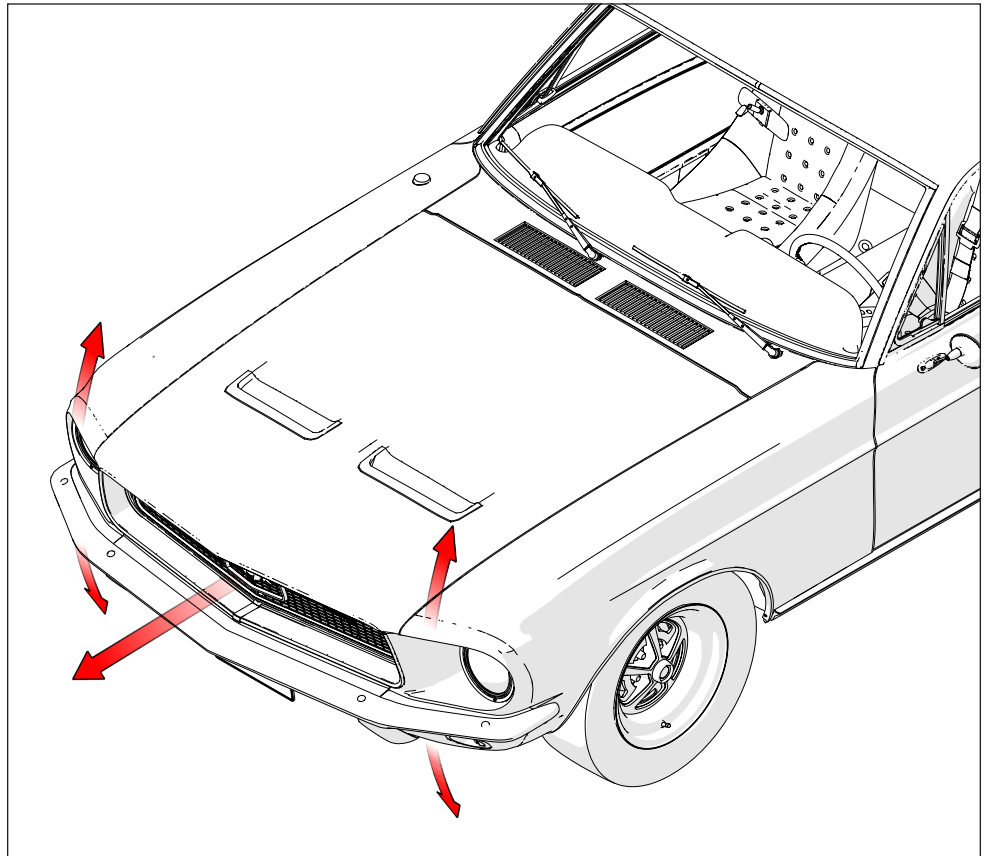

30

For visual clarity, the spindle, brake rotor, hub, and wheel are not shown.

To adjust the height, first raise the car to alleviate the weight on the coil spring seats.

Then, turn the spring seat (shown in red) in either direction with a QA1 T114W or T115W spanner wrench to raise or lower the spring height.

Lower the vehicle and repeat step 27, then check the ride height against the measurements written in the table during step 1.

Raise and repeat the spring seat adjustment until the car is at the desired ride height.

Once the car is at the desired ride height, turn up the seat lock nut (shown in green) and tighten it against the spring seat adjuster.

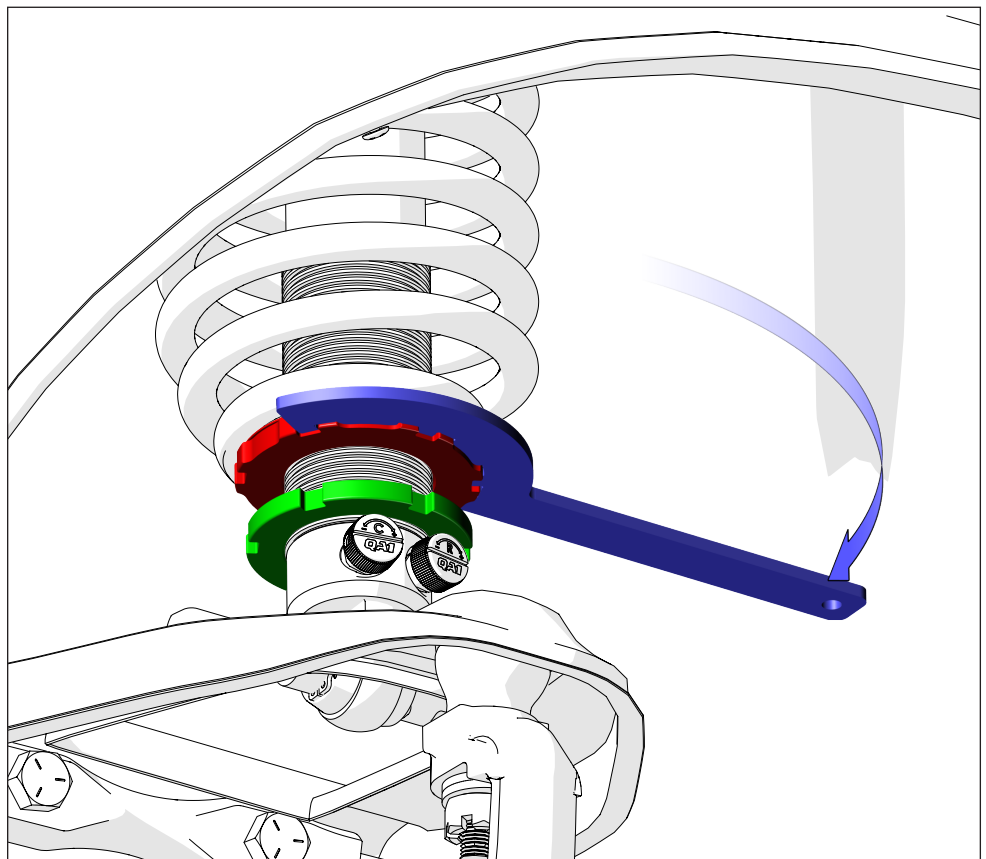

**31** QA1 Single Adjustable (SA) or Double Adjustable (DA) coilovers either have:

18 valving settings on one knob that simultaneously adjust compression and rebound (SA).

18 valving settings on two knobs that independently adjust compression and rebound (DA).

There are 18 damping settings per knob, with six clicks per revolution. Each knob completes three revolutions.

The knob set fully counter-clockwise (-) is the softest setting. Start adjustments from that setting and advance the knob clockwise (+) to add firmness.

The recommended base settings to begin ride testing are shown in the table below.

### MS401/MS402 SHOCKS w/ONE ADJUSTER KNOB

APPLICATION	NUMBER OF CLICKS: COMPRESSION & REBOUND
DRAG RACING	0-6
NICE RIDE & HANDLING	3-6
IMPROVED HANDLING	6-12
AGGRESSIVE HANDLING	13+

### MD401/MD402 SHOCKS w/DOUBLE ADJUSTER KNOBS

APPLICATION	NUMBER OF CLICKS: COMPRESSION	NUMBER OF CLICKS: REBOUND
DRAG RACING	12-18	0-6
NICE RIDE & HANDLING	0-6	2-8
IMPROVED HANDLING	6-12	8-14
AGGRESSIVE HANDLING	13-18	14-18

### DRAG RACE TUNING

CONDITION	SOLUTION
EXCESSIVE FRONT-END RISE	STIFFEN FRONT REBOUND
INADEQUATE FRONT-END RISE	SOFTEN FRONT REBOUND
FRONT-END BOUNCE AFTER LAUNCH	SOFTEN FRONT COMPRESSION, STIFFEN FRONT REBOUND
REAR OF VEHICLE SQUATS	STIFFEN REAR COMPRESSION
REAR TIRES UNLOAD AT APPROX. 60 FT MARK	STIFFEN FRONT COMPRESSION
EXCESSIVE SEPARATION IN REAR	STIFFEN REAR REBOUND
TIRES HOOK AND UNLOAD AT STARTING LINE	STIFFEN REAR COMPRESSION
TIRES SHAKE	STIFFEN REAR REBOUND
IMMEDIATE TRACTION LOSS	STIFFEN FRONT REBOUND, SOFTEN REAR COMPRESSION AND REBOUND

### STREET TUNING

CONDITION	SOLUTION
EXCESSIVE BODY ROLL	STIFFEN FRONT AND REAR REBOUND
EXCESSIVE FRONT-END DIVE	STIFFEN FRONT COMPRESSION
EXCESSIVE REAR-END SQUAT	STIFFEN REAR COMPRESSION
TOO FIRM FRONT	SOFTEN FRONT COMPRESSION AND REBOUND EQUALLY
TOO FIRM REAR	SOFTEN REAR COMPRESSION AND REBOUND EQUALLY
NO WEIGHT TRANSFER DURING ACCELERATION	SOFTEN FRONT REBOUND AND REAR COMPRESSION
NO WEIGHT TRANSFER DURING BRAKING	SOFTEN REAR REBOUND AND FRONT COMPRESSION



HANDLING TUNING	
CONDITION	SOLUTION
CORNER ENTRY	
OVERSTEER	STIFFEN FRONT SUSPENSION
	STIFFEN FRONT COMPRESSION
UNDERSTEER	SOFTEN FRONT COMPRESSION
	SOFTEN REAR REBOUND
MID-CORNER	
OVERSTEER	STIFFEN REAR REBOUND IF REAR SUSPENSION IS UNSTABLE OR HAS EXCESSIVE BODY ROLL.
	SOFTEN REAR REBOUND IF REAR TIRES CHATTER AND LACK SUFFICIENT LATERAL GRIP.
UNDERSTEER	STIFFEN FRONT REBOUND IF FRONT SUSPENSION IS UNSTABLE OR HAS EXCESSIVE BODY ROLL.
CORNER EXIT	
OVERSTEER	SOFTEN REAR COMPRESSION, STIFFEN REAR REBOUND, AND SOFTEN FRONT REBOUND.
UNDERSTEER	STIFFEN FRONT REBOUND AND REAR COMPRESSION

## DISCLAIMER / WARRANTY

QA1 warrants the products to be free from defects in material and workmanship for one year from the date of sale to the original purchaser. QA1 makes no other warranty of any kind, expressed or implied.

QA1 shall have no obligation under the preceding warranty where the defect results from improper or abnormal use, your negligence, vehicle accident, inappropriate or incorrect installation or maintenance, nor when the product has been repaired or altered in any way. QA1's liability in the case of defective products subject to the preceding warranty shall be limited to the repair or replacement of the defective products at QA1's option.

The user understands and recognizes that racing parts, specialized street rod equipment, and all parts and services sold by QA1 are exposed to many varied conditions due to the manner in which they are installed and used. It is the user's responsibility to determine the proper use or application of QA1 products.

QA1 shall bear no liability for any loss, damage, or injury, either to a person or to property, resulting from the installation, direct or indirect use of any QA1 products, or inability by the buyer to determine proper use or application of QA1 products. With the exception of the limited liability warranty set forth above, QA1 shall not be liable for any claims, demands, injuries, damages, actions, or causes of action to the buyer arising out of or connected with using any QA1 products.

Motorsports are inherently risky; therefore, no warranty or representation is made as to the product's ability to protect the user from injury or death. The user is fully aware and assumes that risk.



